

Physics Laboratory

HOC 203

Multimeters and CROs

A-V-Ω Meter (Multimeter)

1. Scale
2. Pointer
3. Zero position adjuster
4. Zero-ohm position adjuster
5. Range selector
6. Full-scale deflection value
7. Input terminals



Taking a reading

- Select a suitable **range** to produce a maximum deflection.
- Range corresponds to the **full-scale deflection (f.s.d.)** of the meter.

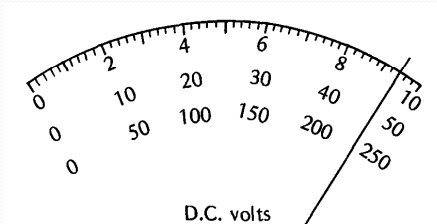

If f.s.d. is 50 V,
then the reading
is **47 V**

A swing coil meter

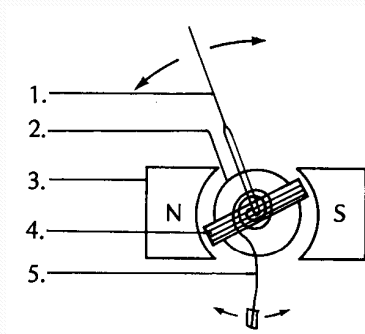

1. The pointer moves with its pivot at the swinging coil
2. An iron core which converges the magnetic field lines
3. Pole piece of the permanent magnet
4. The swinging coil
5. Returning hairspring.

Characteristics

- Input impedance (internal resistance) in the coil determines the current.
- Current in coil produces a torque in the presence of a magnetic field.
- The iron core converges the magnetic lines in the radial direction.
- Shape of the two pole pieces allows field lines to be always parallel to the plane of the coil. Hence torque produced depends only on the strength of the current.
- Deflection of pointer \propto torque produced \propto current flowing in coil \propto applied voltage.

5

Voltmeter

- Large internal resistance (or input impedance for A.C. measurement).
- It usually differs for different ranges. It is about $20 \text{ k}\Omega \text{ V}^{-1}$.
- Can measure D.C. as well as A.C. voltages.
- Internal resistance of various types of voltmeter
 - Vacuum tube voltmeter (VTVM) : $11 \text{ M}\Omega$
 - Cathode ray oscilloscope (CRO) : $10 \text{ M}\Omega$
 - Digital voltmeter (DVM) : $10 \text{ M}\Omega$

6

Effects of internal resistance

- The combined resistance of r & R is always smaller than r or R . Hence the insertion of the voltmeter always lowers the potential between A & B.

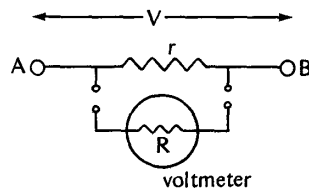

$$\frac{rR}{r+R} \approx \frac{Rr}{R} = r \quad \text{if } R \gg r$$

7

Example

- The voltage across the $1\text{M}\Omega$ resistor is measured by a voltmeter having an internal resistance of $20 \text{ k}\Omega \text{ V}^{-1}$. What are the readings when 10 V f.s.d. and 2.5 V f.s.d. are used?

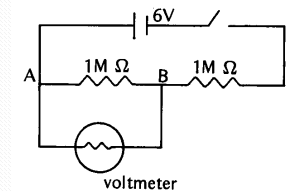

8

10 V f.s.d.

- Internal resistance = $10 \times 20 \text{ k}\Omega = 200 \text{ k}\Omega$.
- Resistance across AB = $\frac{1\text{M} \times 200\text{k}}{1\text{M} + 200\text{k}} = 0.167 \text{ M}\Omega$
- ∴ voltage across AB = $\frac{0.167}{1 + 0.167} \times 6 \text{ V} = 0.86 \text{ V}$

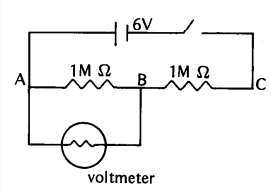

9

2.5 V f.s.d.

- Internal resistance = $2.5 \times 20 \text{ k}\Omega = 50 \text{ k}\Omega$.
- Resistance across AB = $0.047 \text{ M}\Omega$
- ∴ voltage across AB = $\frac{0.047}{1 + 0.047} \times 6 \text{ V} = 0.27 \text{ V}$

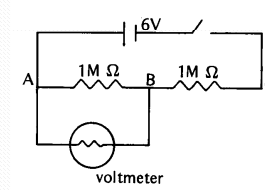

10

Changing Voltage Range

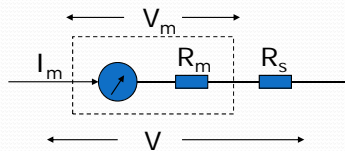

- A series resistor R_s is connected.
- $V \sim I_m(R_m + R_s)$
- e.g. if full scale deflection requires 1 mA , and $R_m = 1000 \Omega$, then full scale voltage is $I_m R_m = 1 \text{ V}$.
- If $R_s = 9000 \Omega$, then full scale deflection occurs at $V = 10 \text{ V}$.

11

To Measure High Tension

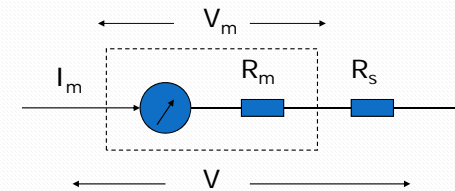

- R_s becomes a high voltage probe with resistance as high as $10 \text{ M}\Omega$ or $100 \text{ M}\Omega$.

12

D.C. and A.C. measurement

- D.C. voltage is applied directly to the swinging coil.
- A.C. voltage has to be converted to D.C. by the following two steps before connected to the coil.
 - Rectification
 - Filtering

13

Rectification

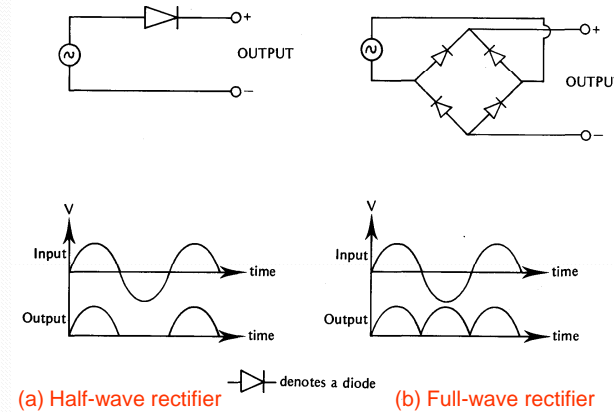

14

Filtering

- A special circuit used to smooth out the oscillating pattern, or **ripples** so that a stable and constant D.C. voltage is fed to the coil.
- The final reading is the **root-mean-squared (R.M.S.)** value of the A.C.

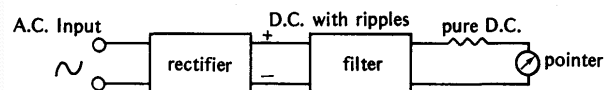

15

Ammeter

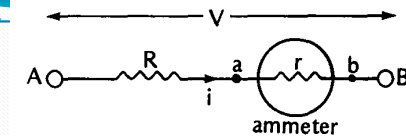

- Very small internal resistance
- Can measure D.C. and A.C. currents
- The addition of the ammeter will inevitably increase the total resistance between AB and therefore lowers the current flow.

$$i = \frac{V}{r + R} \approx \frac{V}{R} \quad \text{if } R \gg r$$

16

D.C. and A.C. current

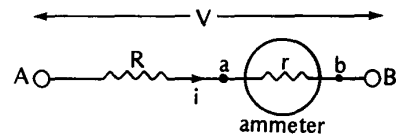

- The ammeter can be thought as a voltmeter measuring the p.d. between points a & b.
- Hence description on D.C. and A.C. voltage measurement is also suitable for d.C. and A.C. current measurement
- Scale is linear, i.e.
deflection \propto magnetic torque \propto current

17

Changing Current Range

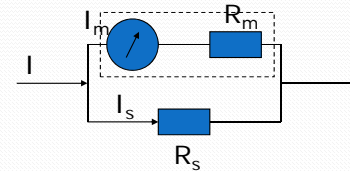

- A shunt resistor R_s is connected.
- Since $I_s R_s = I_m R_m$
 $I = I_m + I_s = I_m + I_m R_m / R_s = I_m (1 + R_m / R_s)$

e.g. if full scale deflection corresponds to 1 mA, then when $R_m = 999 \Omega$ and $R_s = 1 \Omega$, full scale deflection corresponds to ?

1 A

18

A.C. clip-meter

- The wire carrying the A.C. current is clipped by the meter.
- The changing current will produce a changing magnetic flux in the clip, hence inducing an emf in the clip.

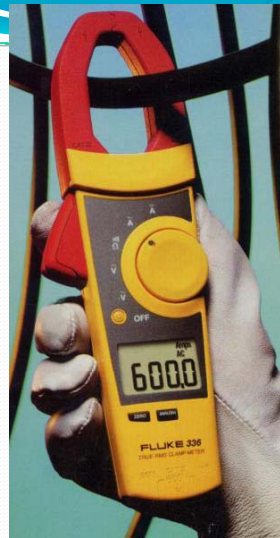

19

Changing magnetic flux

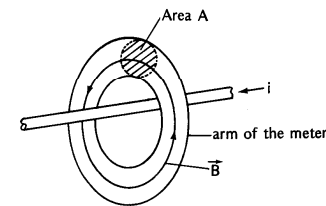

$$\text{Induced emf} = \varepsilon = - \frac{d\Phi}{dt} = - \frac{N \cdot d\vec{B}}{dt}$$

where Φ = magnetic flux enclosed by A

A = cross-sectional area of the coil

B = magnetic flux density

20

Notes on clip-meter

- The wire needs not be placed at the centre of the clip.
- The induced emf is dependent on the rate of change of the magnetic field lines. For use in Hong Kong, it has to be calibrated for 50 Hz.

21

A.C. Parameters

- Peak value: the amplitude or maximum value
- Average value:

$$\bar{i} = \frac{1}{T} \int_0^T i(t) dt \quad \text{and} \quad \bar{V} = \frac{1}{T} \int_0^T V(t) dt$$

- Effective value: If a DC current and an AC current are applied to the same resistor R. Within one period, they produce equal thermal heating:

$$I^2 RT = \int_0^T i^2(t) R dt \quad \text{or} \quad I = \sqrt{\frac{1}{T} \int_0^T i^2(t) dt}$$

$$\text{Similarly,} \quad V = \sqrt{\frac{1}{T} \int_0^T v^2(t) dt}$$

22

Ohm-meter

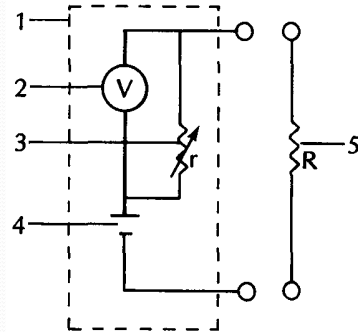

1. Ohm-meter
2. Voltmeter
3. Range selector
4. Internal battery
5. Unknown resistance R

23

Using an ohm-meter

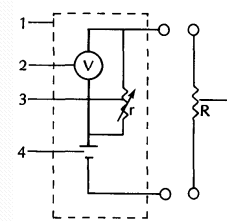

$$V \propto \frac{r}{r+R} \quad \text{where } r \text{ \& } R \text{ are comparable}$$

$$\text{Hence, deflection} \propto \text{current} \propto \frac{r}{R+r}$$

- R & r should be comparable in value, i.e. when R is large, r is also chosen to be large and vice versa.
- Set zero by shorting the two terminals.
- Scale is usually **non-linear**.

24

Scale of an ohm-meter

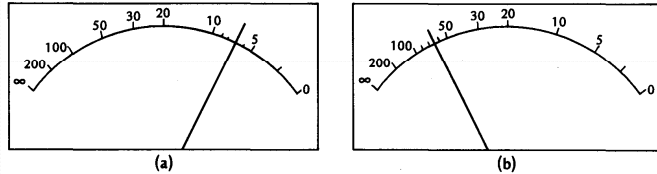

- The resistance is the meter reading multiplied by the range factor.
- In (a), if $\times 10 \text{ k}\Omega$ is used, resistance is $7 \times 10 \text{ k}$ which is $70 \text{ k}\Omega$.
- In (b), the same resistance is measured in the $\times 1 \text{ k}\Omega$ range.

25

Precautions

- Choose the suitable mode – A.C. or D.C., voltage or current or resistance.
- Note that the pointer is at the zero position of the scale when the two input terminals are shorted together. Adjust the position if necessary.
- To measure D.C., connect the terminals such that current enters the meter from the '+' terminal and leaves from the '-' terminal.
- Always start with the range that gives the smallest deflection of the meter. Then decrease the range stepwise until suitable deflection is obtained. Remember that larger deflection gives smaller percentage error.

26

Precautions for ohm-meters

- Adjust the zero-ohm position by shorting the two terminals together.
- Note that the internal battery has its positive pole connected to the '-' terminal of the meter such that current flows out from that terminal to the external resistor. This point is especially important when the meter is used to measure diodes or transistors.
- Do not measure the resistance of a component that is connected to a circuit.
- Always switch off the power supply to that component.
- After measurement, turn the range of the meter to the other modes such as voltmeter or ammeter to prevent accidentally draining the internal battery.

27

Sketch of a Cathode Ray Tube

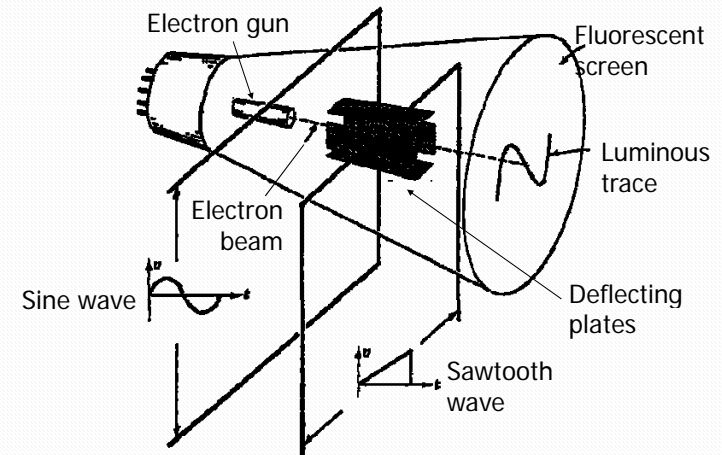

28

Controls of a CRO

- Intensity
- Focus
- Voltage range selector ($V\text{ cm}^{-1}$ or $mV\text{ cm}^{-1}$)
- Time base ($s\text{ cm}^{-1}$, $ms\text{ cm}^{-1}$ or $\mu s\text{ cm}^{-1}$)
- X-shift and Y-shift
- Y-input
- X-input

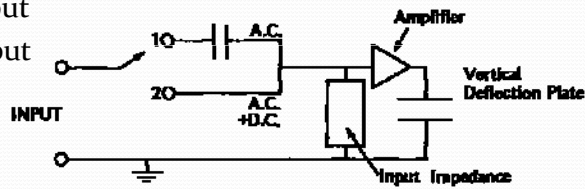

29

Lissajous Figures

- Compare voltages; phases and frequencies

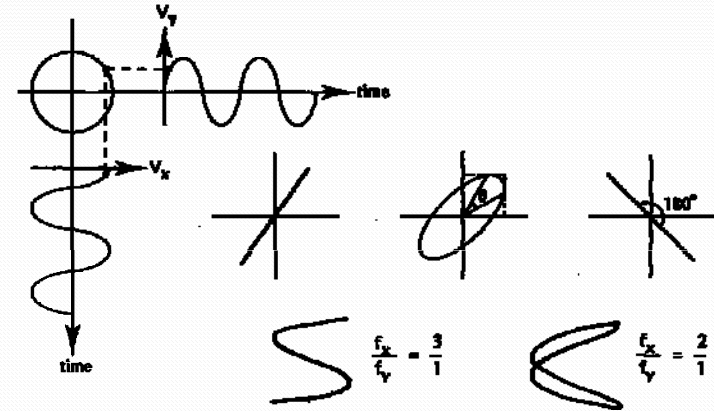

30

Other Controls

- Sweep mode: auto, normal, single
- Source – Ch1, Ch2, line, external
- Coupling – AC, DC, TV, HF rej
- Slope - +ve, -ve
- Triggering level
- Double beam display
 - Alternating mode: good for fast pulses
 - Chopping mode: good for low frequency waves

31